

veritas[®]
Hinge Mortise Plane



05P38.70

U.S. Pat. No. 7,950,157

The Veritas® Hinge Mortise Plane is specifically designed for quickly and accurately cutting shallow mortises, such as those required for butt hinges, strike plates, and the like. The precision blade depth adjustment provides an accurate depth of cut, ensuring an exact mortise depth. The wide mouth offers excellent visibility of layout lines and the long sole spans the mortise.

The spring-loaded blade-clamping collar holds the blade in position when the collar is loosened and provides tactile feedback for controlled blade depth adjustment. The collar can also be made to fully release for quick and easy blade removal.

The ductile cast iron body has been accurately machined and ground flat. The large wooden knobs are positioned to provide both comfort and excellent control.

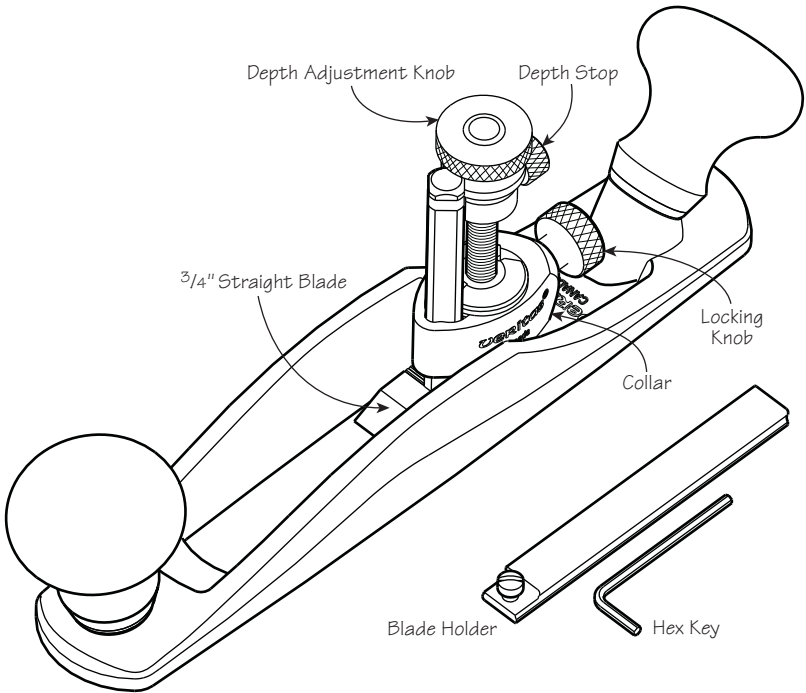



Figure 1: Hinge mortise plane components.

Blade Attachment

 **Caution:** Be aware that the blade is sharp; careless handling can result in serious injury.

The plane comes equipped with a $\frac{3}{4}$ " straight blade. Back off the locking knob and press it forward to depress the internal spring. Feed the blade up through the collar from the bottom of the plane, engage the slot at the top of the blade with the flange at the base of the depth adjustment knob, and secure by tightening the locking knob. If the blade slot does not engage with the adjustment knob, back off the locking knob until it does.

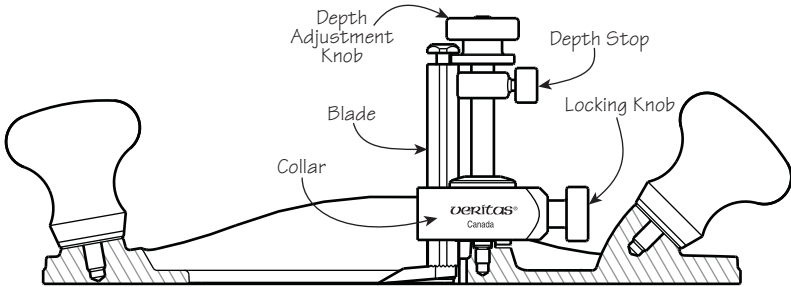

Figure 2: Blade attachment.

Note: The $\frac{3}{4}$ " straight blade will fit on the Veritas® Router Plane, just as all of its blades will fit on the Veritas Hinge Mortise Plane.

Blade Adjustment

The blade depth is regulated by a fine screw feed that travels $\frac{1}{32}$ " per turn for precision adjustment with the resulting depth of cut controlled by the depth stop. The blade can be adjusted to a depth of 1".

Release the clamping pressure by backing off the locking knob a quarter turn. (Spring pressure will be maintained to prevent the blade from falling free while allowing it to be adjusted.) Turn the depth adjustment knob to advance or retract the blade as required. Reclamp the blade by tightening the locking knob.

Set the blade for a "zero" depth of cut. Place the hinge leaf between the flange on the depth adjustment knob and the depth stop. Raise the depth stop until it makes contact with the hinge leaf.

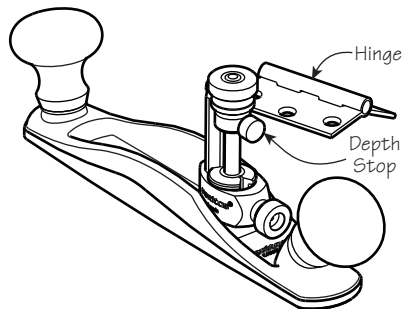

Figure 3: Setting the depth stop.

Laying Out and Cutting a Hinge Mortise

Position the hinge in the desired location on the workpiece and lay out the mortise by tracing the outer edges of the hinge leaf with a marking knife or fine pencil.

Deeply score the perimeter of the mortise with a chisel or heavy knife. For deep mortises, you will need to repeat this process as the cut progresses.

With the hinge mortise plane set to take a medium-depth cut (about a half turn from the “zero” setting), begin to plane out the waste material. Work up to the score lines until the entire mortise is at the same depth.

Reset the blade for a deeper cut and repeat the removal of waste material. As the cut approaches full depth, use progressively smaller cut depths. When the depth stop contacts the flange, the mortise is complete.

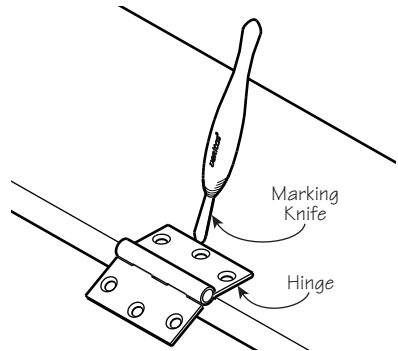

Figure 4: Laying out the hinge mortise.

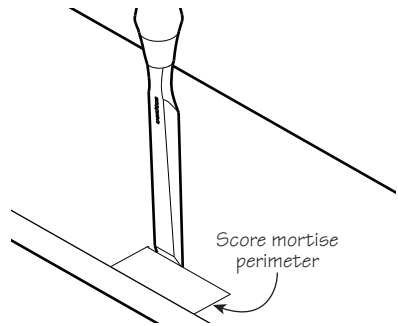

Figure 5: Scoring the mortise perimeter.

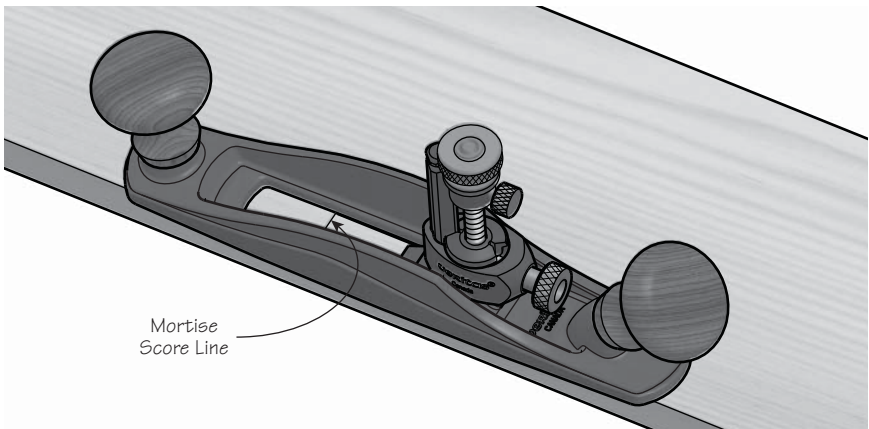

Figure 6: Cutting the mortise.

Blade Sharpening

For ease of sharpening, the blade portion may be removed from the shaft. Whether removing or reattaching the blade, be careful of the sharp edge. **Do not** hold the blade shaft in your hand while loosening or tightening the set screw. Clamp the shaft in a vise or hold it down on a flat surface, as shown in **Figure 7**. Remove the set screw that secures the blade portion to the shaft with the supplied hex key.

Attach the blade to the holder with the small screw provided. The blade holder can be mounted in a honing guide or used for sharpening by hand. Hone the bevel as illustrated in **Figure 8**, and flip over to lap the back.

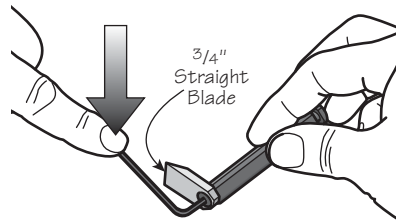

Figure 7: Removing blade from shaft.

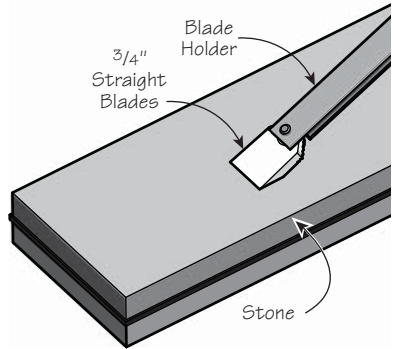

Figure 8: Honing the blade.

Care and Maintenance

The body of this plane is ductile cast iron and comes treated with rust preventative. Remove this using a rag dampened with mineral spirits. Clean all machined surfaces.

We recommend that you initially, then periodically, apply a light coat of silicone-free paste wax to seal out moisture and prevent rusting (as well as act as a lubricant for smoother planing). Wipe off any wood dust from the surfaces that you will be waxing, apply a light wax coating, let dry, then buff with a clean soft cloth. At the same time, the solvents in the wax will remove any harmful oils left from your fingers that can lead to corrosion. This is especially important with planes that are gripped on the machined surfaces.

Before treating a plane with a sealant, wipe off any fingerprints with a cloth dampened with a small amount of light machine oil. Remove any residual oil; then apply the sealant to the plane's sole.

If storage conditions are damp or humid, the plane should, in addition to the treatment outlined above, be wrapped in a cloth or stored in a plane sack. This precaution will also guard against dings and scratches.

Every so often, clean all parts with a cloth dampened with a dab of light machine oil and lubricate where necessary. For corroded plane bodies, we recommend you first remove the rust with a fine rust eraser, and then treat as described above.

The bright finish on the brass components can be maintained as above. If a patina finish is preferred, simply leave the brass components unprotected until the desired level of oxidation has occurred, then apply a sealant. If you want to make them bright and shiny again, you can revitalize the surface with a brass polish.

Accessories

05P38.71	3/4" Straight Blade
05P38.04	1/2" Straight Blade
05P38.05	1/2" Pointed Blade
05P38.23	3/32" Narrow Straight Blade
05P38.24	1/8" (3mm) Narrow Straight Blade
05P38.26	3/16" Narrow Straight Blade
05P38.03	1/4" Narrow Straight Blade
05P38.34	4mm Narrow Straight Blade
05P38.35	5mm Narrow Straight Blade
05P38.36	6mm Narrow Straight Blade

veritas[®] Tools Inc.

814 Proctor Avenue 1090 Morrison Drive
Ogdensburg NY 13669-2205 Ottawa ON K2H 1C2
United States Canada

customerservice@veritastools.com

www.veritastools.com