

The Veritas® Large Fence Flip Stop can be secured at any point along a 1/4-20 tape T-slot track and flipped up out of the way when not needed. A micro-adjust screw at the tip of the stop arm lets you fine-tune stock positioning.

### Calibration of the Graduated Tape on the Tape T-Slot Track

The first thing you will need to do is determine where to affix the graduated tape on your 1/4-20 tape T-slot track relative to your machine (e.g., miter saw).

1. To make your test workpiece, cut a scrap piece of wood to an exact known length (e.g., 15"), making sure it is long enough to extend out to the installed 1/4-20 tape T-slot track as well as past the saw fence.
2. Place the test workpiece against the fence such that one end touches the saw blade.
3. Install the large fence flip stop on the 1/4-20 tape T-slot track (as shown in **Figure 1**), slide it along the track until it registers against the other end of the board and tighten the knob to lock it into position. *Note: The micro-adjust screw should be proud of the stop arm by approximately 1/8" to allow for final adjustment in either direction.*

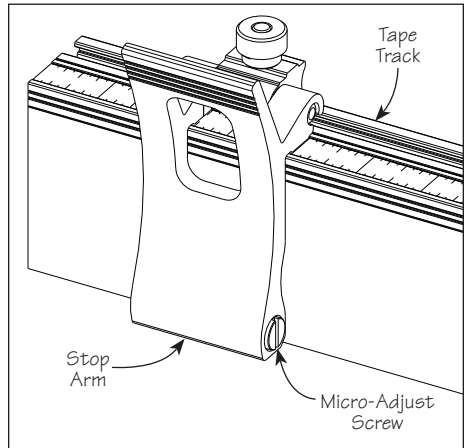

**Figure 1: Large flip stop components.**

4. Using a pencil, mark the location of the stop arm on the track in front of the tape pocket, as shown in **Figure 2**.
5. Remove the large fence flip stop and apply the graduated tape to the track such that the appropriate mark on the tape (e.g., 15") is aligned with the pencil mark.

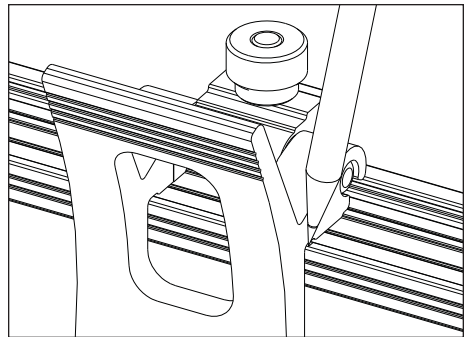

**Figure 2: Marking the track.**

6. Reinstall the large fence flip stop on the track and position it to a desired setting. Cut another scrap piece of wood, measure the result and compare it to the setting. If required, you can fine-tune the stock positioning with the micro-adjust screw and retest.

Veritas® Tools Inc.

814 Proctor Avenue      1090 Morrison Drive  
 Ogdensburg NY 13669-2205      Ottawa ON K2H 1C2  
 United States      Canada

customerservice@veritastools.com  
[www.veritastools.com](http://www.veritastools.com)